

# MODEL DC-50B

## Digital Spark Tester

- Split electrode design for easy string-up
- DSP based voltage regulation and differentiation of four fault-types
- LED display viewable up to 200 feet away
- Customizable front panel password security
- Voltage Watchdog
- Communications: Modbus RTU via RS-485  
Optional: Analog, Ethernet/IP, Modbus TCP, Profibus, PROFINET, DeviceNET

The Clinton model DC-50B DC Spark Tester combines the latest in technology and innovative features for DC spark testing of wire and cable.

Using DSP based fault typing the DC-B can differentiate between four fault conditions: pinhole, direct metal contact, multi-pinhole and gross bare wire.

The DC-50B split electrode designs provide an easy way to string-up wire through the electrode, guaranteeing precise center alignment for the most effective and reliable testing. The bead chain assemblies are positioned to eliminate gaps between bead rows, providing the best coverage around the product at all times.

The DC-50B can be quickly configured for extrusion or re-spooling or operations through a simple configuration menu on the alphanumeric display. During spark testing, critical data such as test voltage, percent load, and counts for particular fault types can be easily accessed. Additionally, descriptive codes inform the operator when there is an error. For example, when the protective electrode cover is open.

The display module can be mounted to the unit as shown, or can be installed up to 200 feet away, with an optional longer interconnecting cable.

**Clinton**  
INSTRUMENT COMPANY

DC-50B/BD-12S with RC Control



The DC-B can connect easily to a PLC with Modbus RTU via RS-485 full duplex. Optional Analog, DeviceNET, Ethernet/IP, PROFINET, Profibus, and Modbus TCP communications are available.

Wiring and setup are done externally; there is no need to open the unit. One form C and three form A relay contacts are located on the rear panel for easy connection to external alarms, lights, or machinery controlled by the spark tester.

Relay function may be selected from options including: high voltage ON indication, fault alarm, bare wire alarm, and voltage watchdog (when enabled, the equipment will alert when a preset upper or lower voltage is exceeded).

The DC-B features a flexible front panel password security, locking out unauthorized changes to test voltage and other settings. The unit also monitors output voltage at the electrode and notifies the operator if voltage at the electrode should become disconnected.

The DC-B spark tester series offers standard electrodes that meet UL, CSA, and all known international standards for wire products and production line speeds. Specifically designed electrodes are available to accommodate a wide range of product sizes and shapes.

# DC-50B

## SPECIFICATIONS

<b>Voltage Test Range:</b>	1000 Volts to 50kV DC
<b>Voltage Accuracy</b>	+/- 2% of reading
<b>Output Power</b>	6.0 mA maximum
<b>Fault Indication</b>	White 3-digit 20.32mm high LED display, amber fault indicating LED
<b>Fault Resolution</b>	Variable with electrode length or directly configurable from 1 millisecond to 2 seconds
<b>Detection Sensitivity</b>	Conforms to IEC 62230
<b>Operating Modes</b>	Continuous HV/remove voltage on fault, momentary process control/latch until reset
<b>Relay Outputs</b>	1 Form C, 3 Form A / Configurable Functionality Relay contacts rated 1A max @ 240VAC or 2A max @ 120VAC for both NO and NC circuits. Front panel or external reset. In non-latch modes, closure time is adjustable in 10 millisecond increments from 50 milliseconds to 2 1/2 seconds

# DC-B

## ELECTRODES

<b>Power Requirements</b>	100 to 240VAC 49-61 Hz. Power supply self-adjusting
<b>Safety</b>	Designed to IEC-1010
<b>Communications</b>	Modbus RTU via RS-485
<b>Optional Communications</b>	Analog, Ethernet IP, Modbus TCP, Profibus, Profinet, DeviceNET
<b>Bead Chain Assemblies</b>	
BD-A406	Bead Chain Assembly 4" Product Diameter, 6" along the wire line.
BD-A506	Bead Chain Assembly 5" Product Diameter, 6" along the wire line.

### Dimensions for DC-50B with RC Display Mounted

### Rack Mounted RC

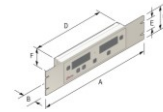

A	19.0"	[483 mm]
B	1.8"	[46 mm]
C	3.5"	[89 mm]
D	11.2"	[285 mm]
E	1.8"	[45 mm]
F	3.1"	[79 mm]

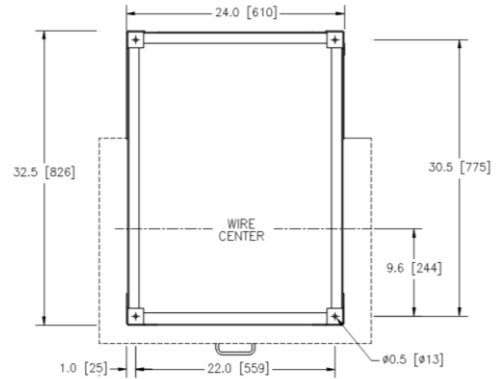
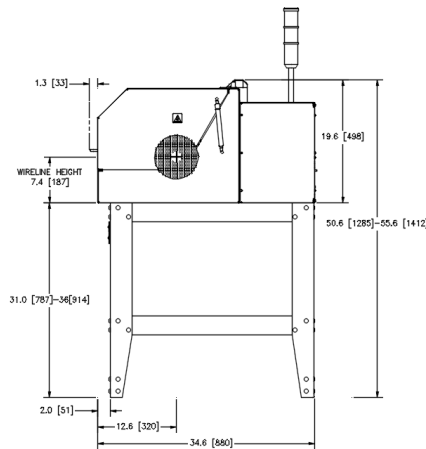
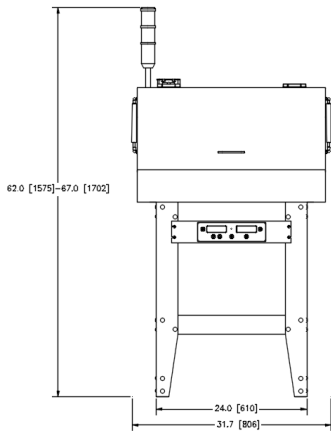

For additional dimension information please contact the factory for model specific outline dimension drawings.

